

SOLUZIONE WALK-IN

SW1 - Sopra vasca Walk-In

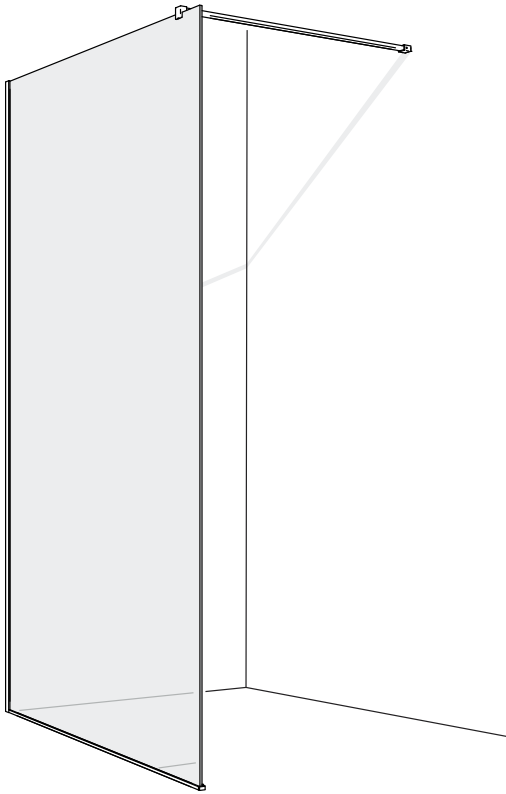

Per una corretta installazione del prodotto e validità della garanzia, seguire accuratamente le istruzioni di montaggio riportate nel presente manuale.

For a correct installation of the product and for the validity of the guarantee, follow carefully assembly instruction reported in the present manual.

NO

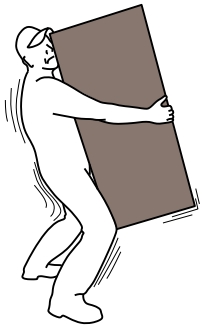

OK

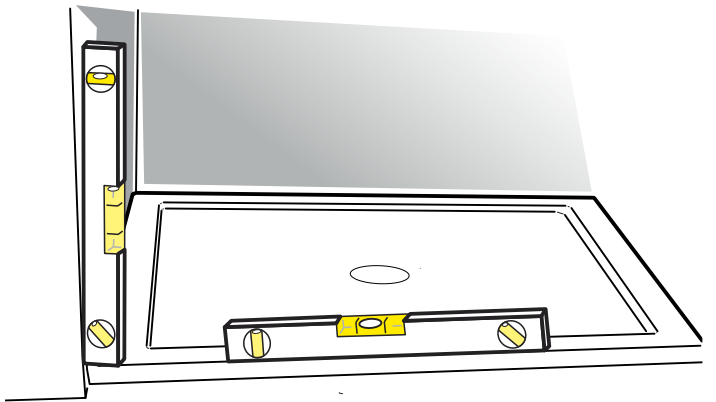
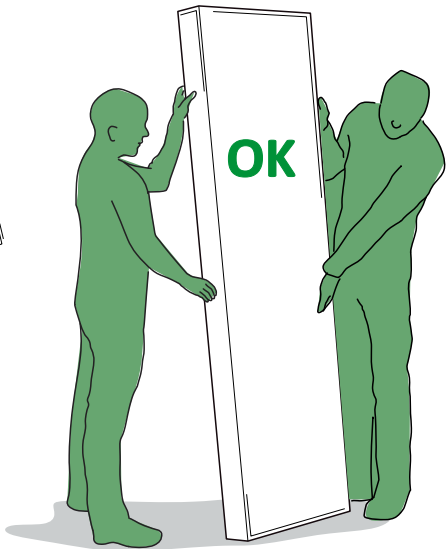

1 Prima di procedere all'installazione, verificare che il modello ricevuto sia conforme a quello ordinato, controllando l'etichetta sulla confezione. Durante il trasporto e il montaggio maneggiare il prodotto con cura.

L'acquirente è tenuto a verificare l'integrità del prodotto prima dell'installazione, segnalando eventuali anomalie o non conformità al Rivenditore Autorizzato: il mancato rispetto di quanto sopra può provocare l'immediato decadimento della garanzia.

Before to proceed with the installation, check that the model received is as per the one ordered, checking the label on the packaging. During transport and installation handle the product with care.

The purchaser must check the integrity of the product before installing, reporting to the authorized seller possible fault or non compliance: Not doing the aforementioned check or report it can cause the immediate decline of the guarantee



2 Prima di procedere all'installazione verificare che il piatto doccia sia in bolla (orizzontale e planare) e le condizioni in cui si trovano la parete di luce ed acqua. In caso di montaggio su piatti storti o non planari, non si garantisce il corretto funzionamento della cabina.

Prima di procedere al montaggio della cabina accertarsi che non siano state richieste modifiche all'installazione standard (come sostituzione di braccetti, misure particolari, profili particolari, ed altro).

Before proceeding to the installation, check that the shower tray is levelled (horizontal and planar) the wall condition and position of electrical wiring and water piping. In case of installing on shower tray not straight or levelled, does not guarantee the correct functioning of the enclosure.

Before proceeding to the installation of the enclosure make sure that have not been made request of changes to the standard installation (like replacement of brackets, particular measures, etc.).

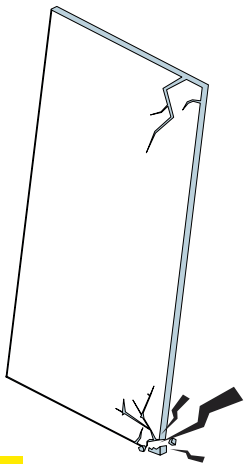

NO

MANEGGIARE CON CURA

**TEMPERED
GLASS**

HANDLE WITH CARE

OK

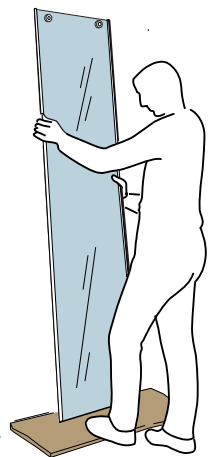

3 Manovrare con cautela le parti vetrate poiché l'urto con una superficie dura o con spigoli potrebbe causare la frantumazione del cristallo (secondo le norme UNI EN 14428).

Non disperdere o lasciare alla portata dei bambini i materiali d'imballo (sacchetti in plastica, viti ed altri elementi di minuteria) in quanto possono essere potenziale fonte di pericolo, per lo smaltimento del prodotto o dei suoi componenti attenersi ai regolamenti locali in materia di smaltimento rifiuti. Per assistenza nel montaggio, richiesta di ricambi o accessori Originali, si prega di interpellare il Rivenditore Autorizzato.

Handle with care the glass part the impact with solid surface or corners can cause the shattering of the glass (according to the UNI EN 14428 norm). If you are not sure of this, contact the person that has transmitted the order.

Do not waste or leave the packaging material (plastic bags, screws and other bits and pieces) to the reach of children because they are source of danger, for the disposal of the product and of its components please refer to the local rules in themes of waste disposal. For the assistance of the installation, request of spare parts or original accessories, please contact the authorized seller.



Tutte le parti che compongono il prodotto devono essere pulite utilizzando un panno morbido leggermente inumidito a detergenti liquidi a base neutra. Non usare detergenti particolarmente aggressivi: l'utilizzo di tali prodotti potrebbe causare l'opacizzarsi delle finiture cromo o verniciate. Non usare getti di vapore: le giunzioni in materiale plastico potrebbero subire forti shock termici che causerebbero l'immediata frantumazione degli stessi. Il trattamento AQVACLEAN sulle superfici in cristallo è realizzato sia dalla parte interna che dalla parte esterna: per la pulizia della lastra si consiglia di utilizzare un panno morbido leggermente inumidito. Quando il trattamento va esaurendosi è disponibile il «kit di ripristino trattamento AQVACLEAN» (in vendita presso i Rivenditori Autorizzati). Non usare assolutamente detersivi o panni abrasivi (scotch-bride), solventi o altre sostanze chimiche aggressive.

All the parts that compose the product must be clean by mean of a soft cloth slightly damped with neutral base mild detergent. Do not use detergent that are particular aggressive: the use of such product could cause the opacify of the chrome or varnish finish. Do not use steam jet: the jointing in plastic material can undergo to very much thermic shock that could cause the immediate shattering of the elements. The AQVACLEAN treatment is made on inside and outside surface of the glass : For the cleaning of the surface is recommended a soft cloth slightly damped with water. When the treatment is fading away is available <the restoration AQVACLEAN treatment kit> (Available to Authorized sellers). It is forbidden the use of abrasive soap or cloth (ei. Scotch-bride), solvent or other aggressive chemical substance.

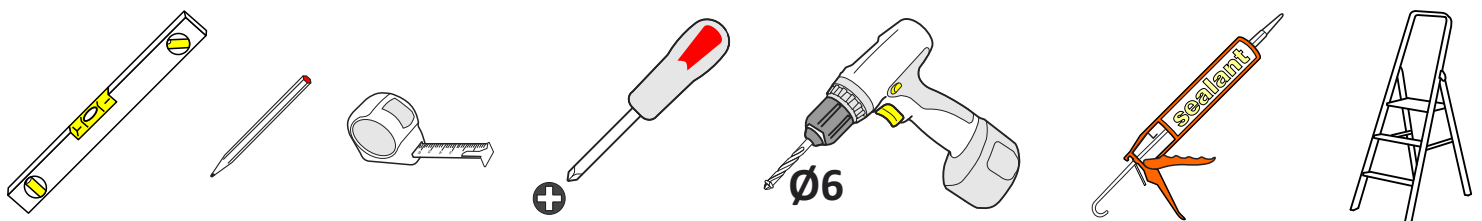

UTENSILI PER IL MONTAGGIO REQUIRED ASSEMBLY TOOLS:

- Livella / water level
- Matita / Pencil
- Flessimetro / Fleximeter
- Cacciavite a croce
Cross-shaped screwdriver
- Trapano / Drill
- Punta per murature 6 mm / Drill 6 mm
- Silicone / Silicon
- Scala 3 gradini / Staircase 3 steps



GARANZIA

Il costruttore garantisce i propri prodotti da difetti di fabbricazione per 24 mesi, con decorrenza dalla data di acquisto comprovata dalla ricevuta o scontrino fiscale. La garanzia è valida solo se le conformità dichiarate sono riconducibili a difetti di fabbricazione e sono state riconosciute dal costruttore. Un'installazione che non segue le fasi riportate nel presente manuale d'uso, causa l'immediata scadenza della garanzia. Sono esclusi dalla garanzia le parti soggette a normale usura e/o componenti che dovessero risultare difettosi o danneggiati a causa di danni accidentali per incuria o inadeguato trattamento, per uso ed installazione errati od impropri, e da successive manipolazioni o modifiche eseguite da personale non autorizzato dal costruttore e/o dalla loro esposizione ad agenti corrosivi e/o abrasivi anomali. Il costruttore declina da qualsiasi responsabilità a danni a persone, animali o cose, causati da errori d'installazione, di regolazione o imperfetto utilizzo o la mancata osservanza di tutte le prescrizioni contenute nel presente manuale d'uso e manutenzione che accompagna il prodotto.

WARRANTY

The manufacturer guarantees its product from manufacturing defects for 24 months, starting from the date of purchasing proved by the receipt or fiscal slip. The guarantee is valid only if the conformity declared are referable to defects of manufacturing and have been acknowledged by the manufacturer. An installation that does not follow up the steps reported in the present installation manual, cause the immediate expiry of the guarantee. Are not included in the guarantee the parts that are subject to normal wear and tear and /or components that results faulty or damaged due to accidental damage for negligence or inadequate care, for use and incorrect or improper installation, and from subsequently handling or changes made from unauthorized personnel of the manufacturer and/or to the exposition to corrosive and/or abrasive agents. The manufacturer declines from any responsibility to damages towards persons, animals or things caused from mistakes of installation, adjustment or to incorrect use or lack observance of all the regulation contained in the present manual of use and maintenance that accompany the product.

D.P.I.





ATTENZIONE! Nell'imballo trovate il vostro box doccia in tutte le sue parti e per una corretta installazione e validità della garanzia,

SEGUIRE

attentamente le istruzioni di montaggio di seguito riportate.

ATTENTION! In the packaging you will find your shower enclosure in all its parts and for a correct installation and validity of the warranty,

FOLLOW

carefully assembly instruction below.

COMPONENTI BOX DOCCIA
SHOWER BOX COMPONENTS

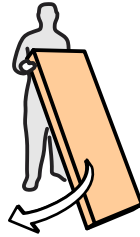

Profili e accessori box doccia

Profiles and accessories shower enclosure

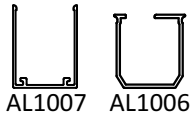

AL1007

AL1006



PG6011

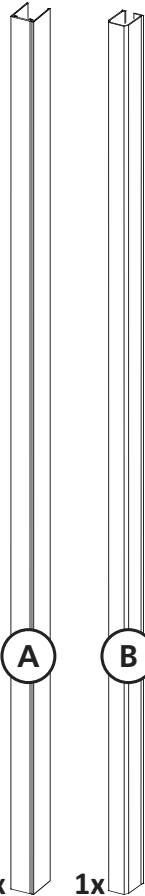

A

1x



B

1x



C

1x



D1

1x



D2

1x

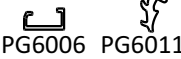

PG6006

PG6011



AF

1x

ANTA FISSA / FIXED DOOR

V1



4x BA126

Fisher ø 6 mm

V2



4x VT1102390380

3,9 x 38 mm Autofilett.

E1



1x AL6142

E2



1x AL6143

F



1x AL6140

1x SLK2070

Kit barra trasversale

Cross bar kit

G

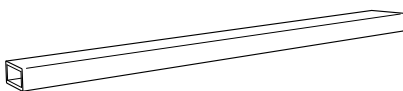

1x BA6146

Barra/Bar 20x10

STANDARD L=120 cm riducibile/reducible

H1



1x SL2070

H2



1x SL2071

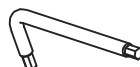

1x TOOL 4 mm

V1



1x BA126

Fisher ø 6 mm

V2



1x VT1102390380

3,9 x 38 mm Autofilett.

V3



2x VT3102350095

3,5 x 9,5 mm Autoperf.

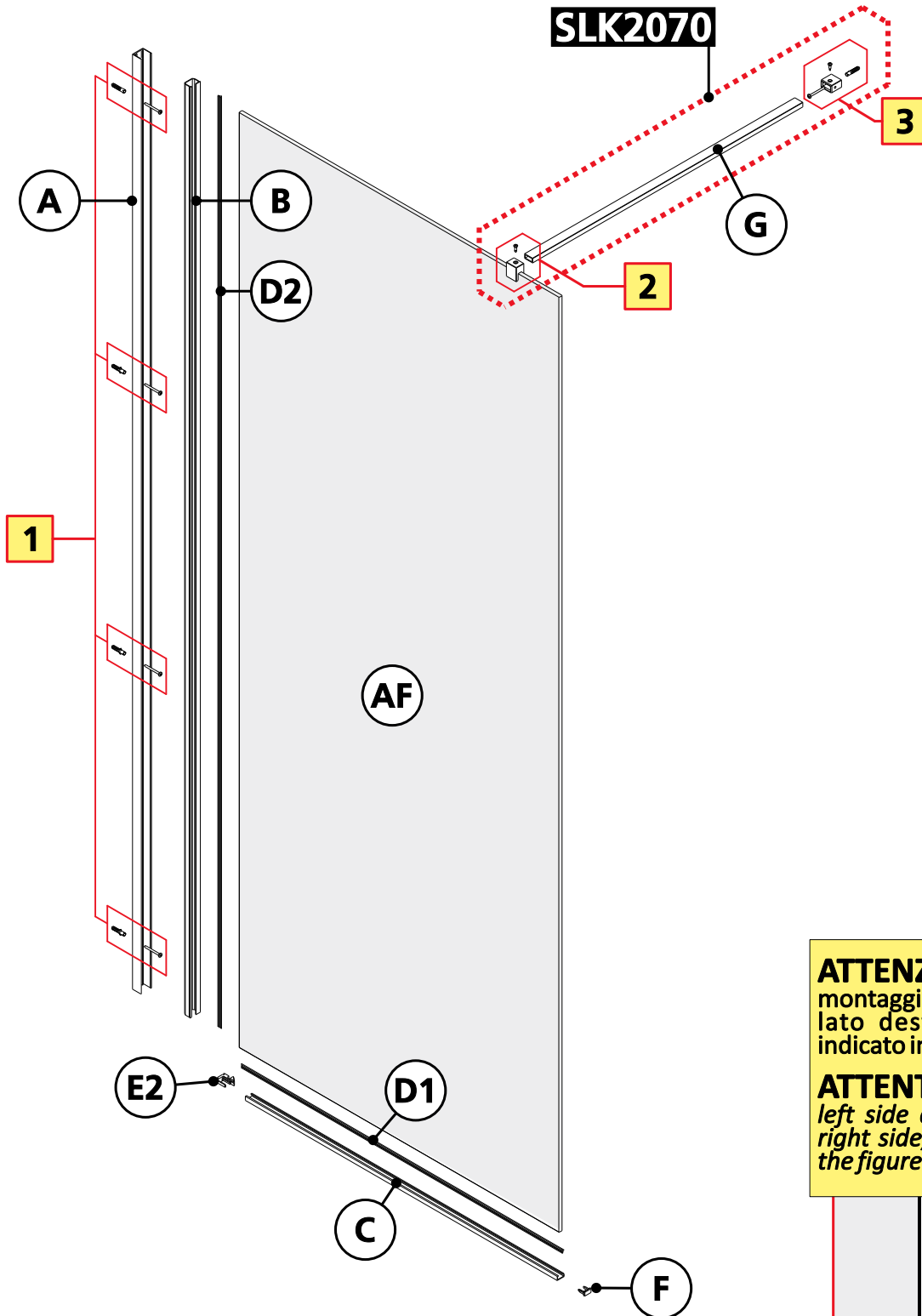
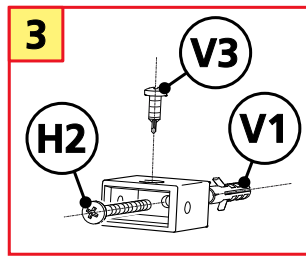
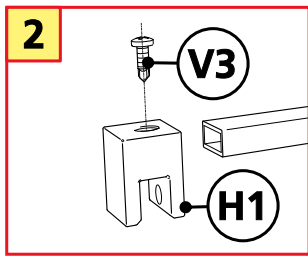
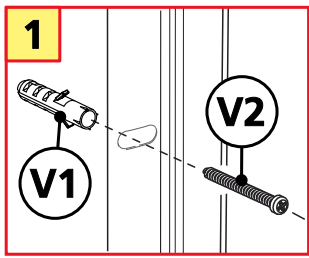

RIF.	COD. / IMG.
(A)	AL1007
(B)	AL1006
(C)	PG6006
(D1)	PG6011
(D2)	PG6011
(E1)	AL6142
(E2)	AL6143
(F)	AL6140
(G)	BA6146 STANDARD L=120 cm
(H1)	SL2070
(H2)	SL2071
(V1)	BA126 Fisher ø6
(V2)	VT1102390380 3,9x38 mm
(V3)	VT3102350095 3,5x9,5 mm

ATTENZIONE! Lo schema è riferito al montaggio lato sinistro. Per il montaggio lato destro usare l'accessorio come indicato in figura.

ATTENTION! The scheme refers to the left side assembly. For mounting on the right side, use the accessory as shown in the figure

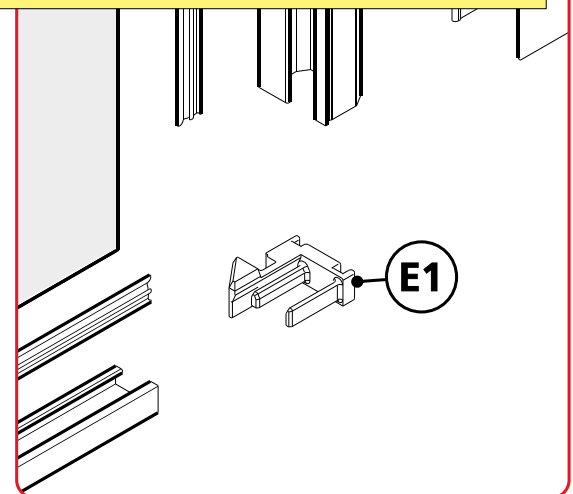

1

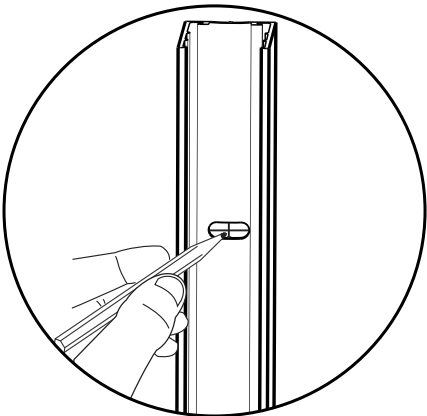
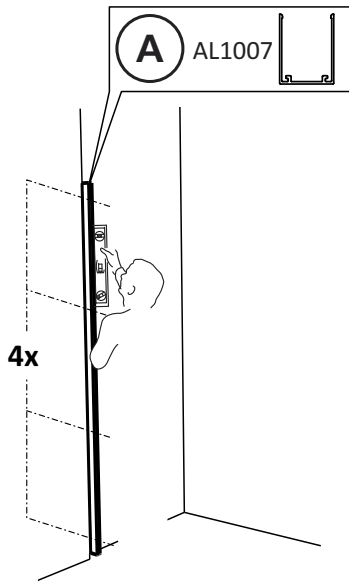

2

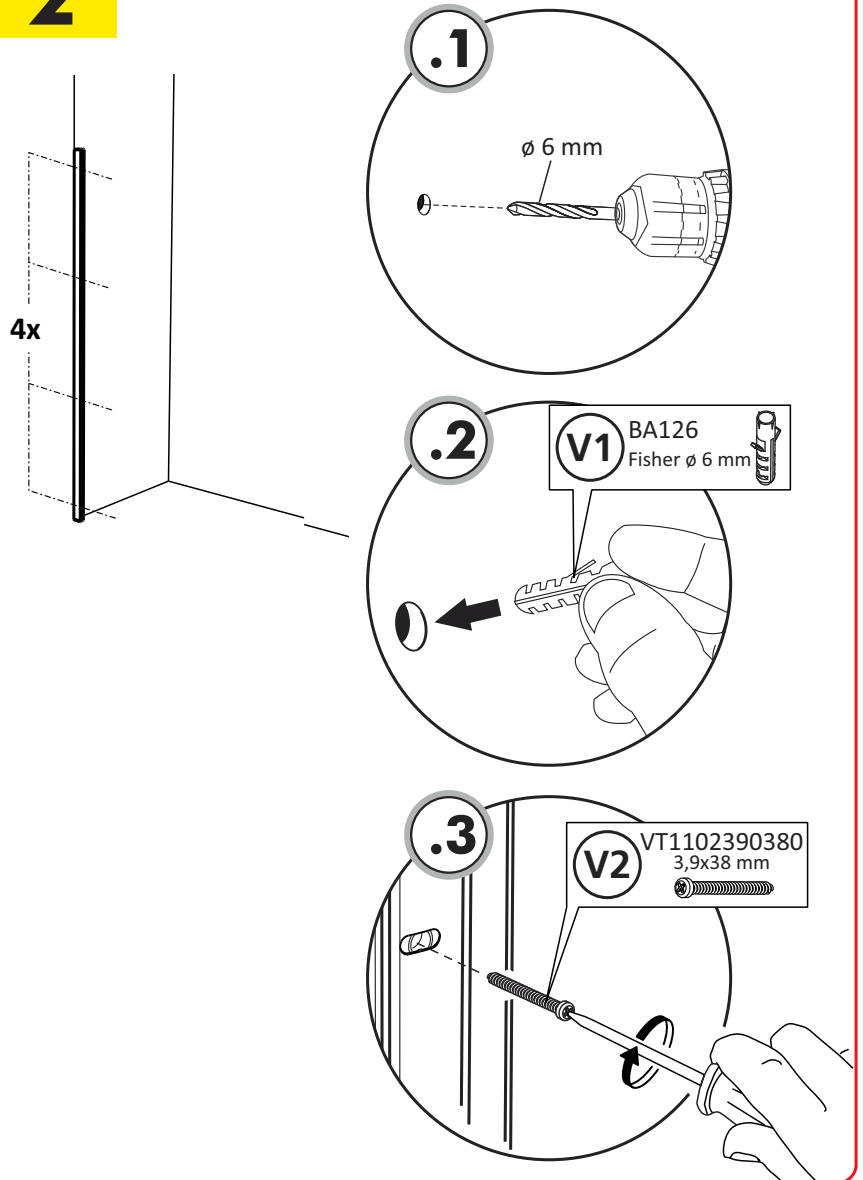

3

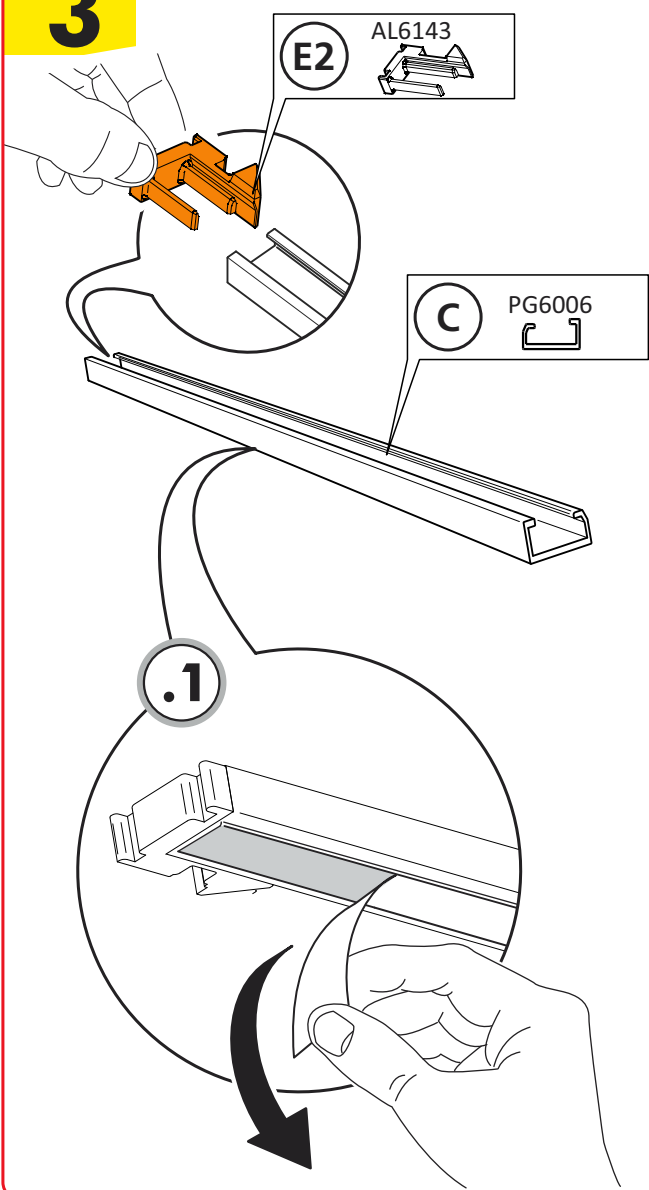

4

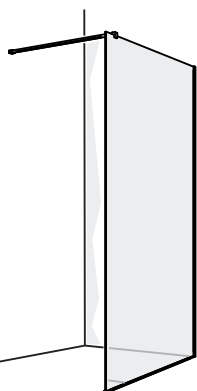
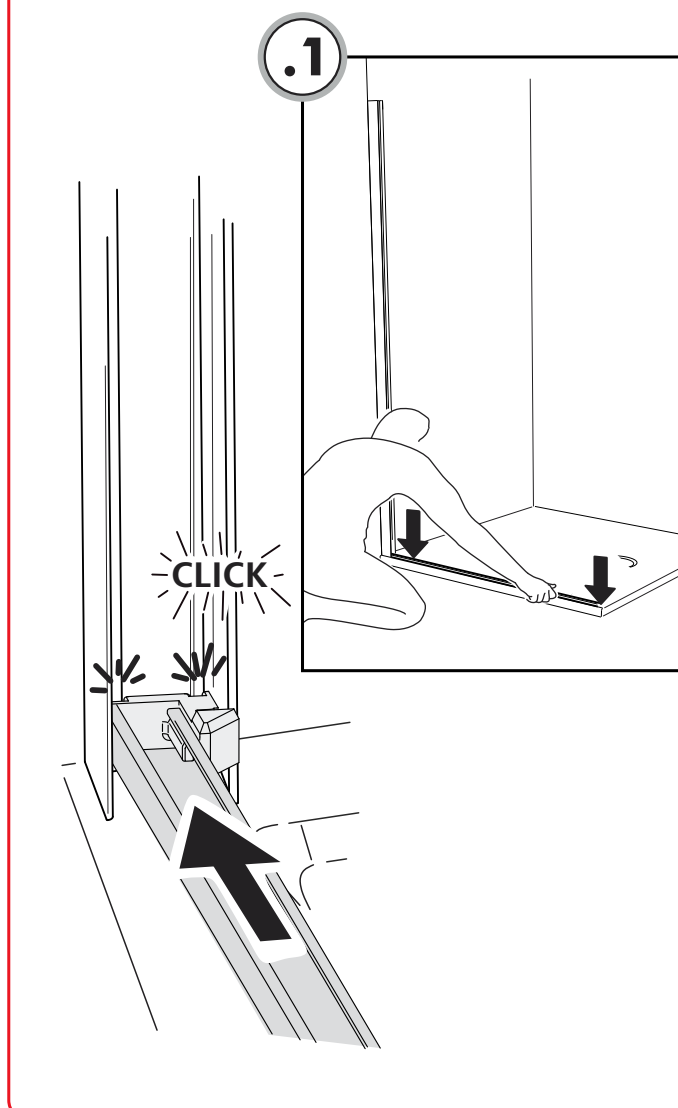

ATTENZIONE! Per il montaggio lato destro usare l'accessorio come indicato in figura.
ATTENTION! For mounting on the right side, use the accessory as shown in the figure

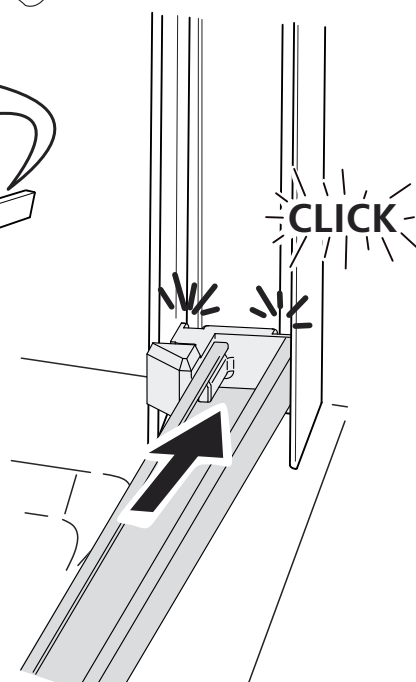
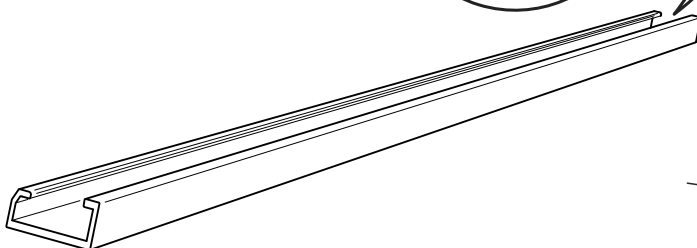
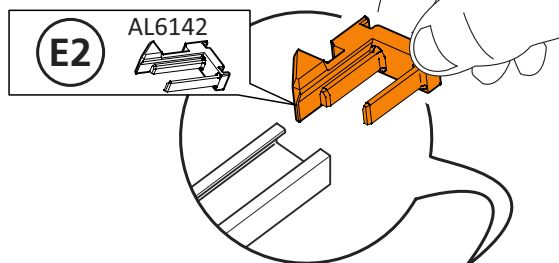

5

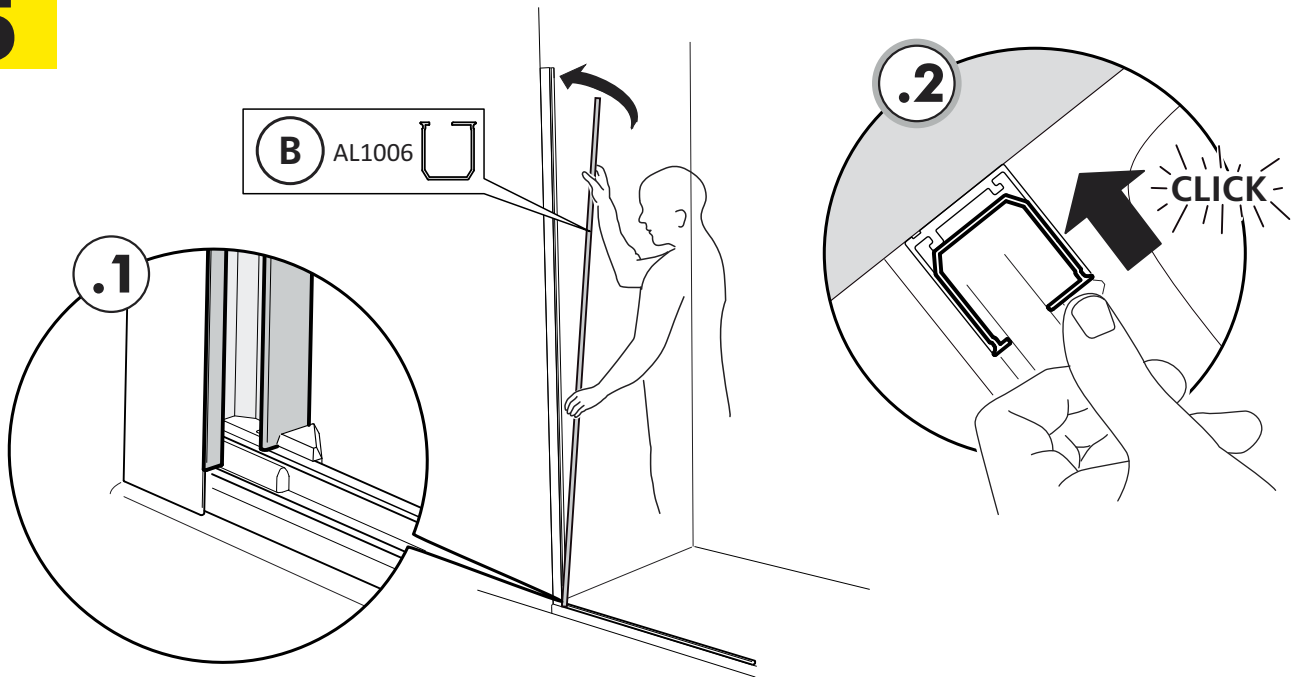

6

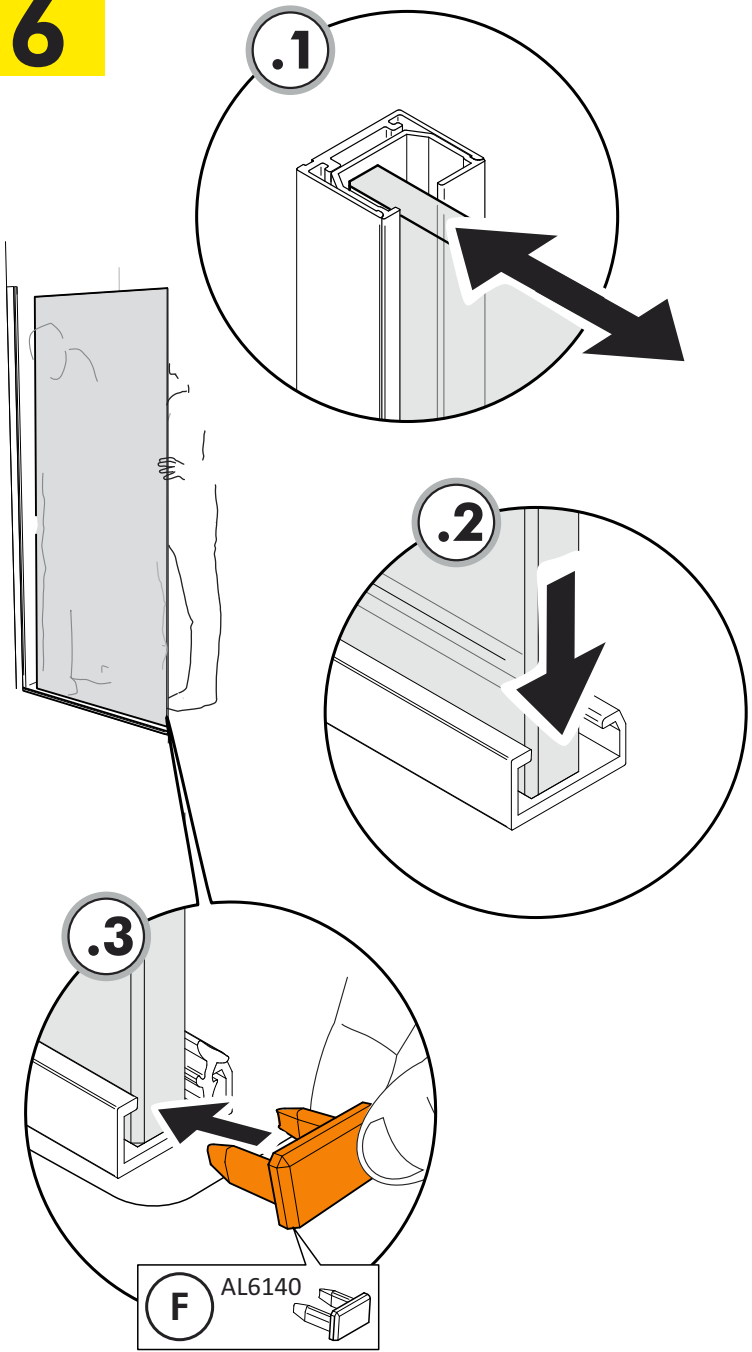

7

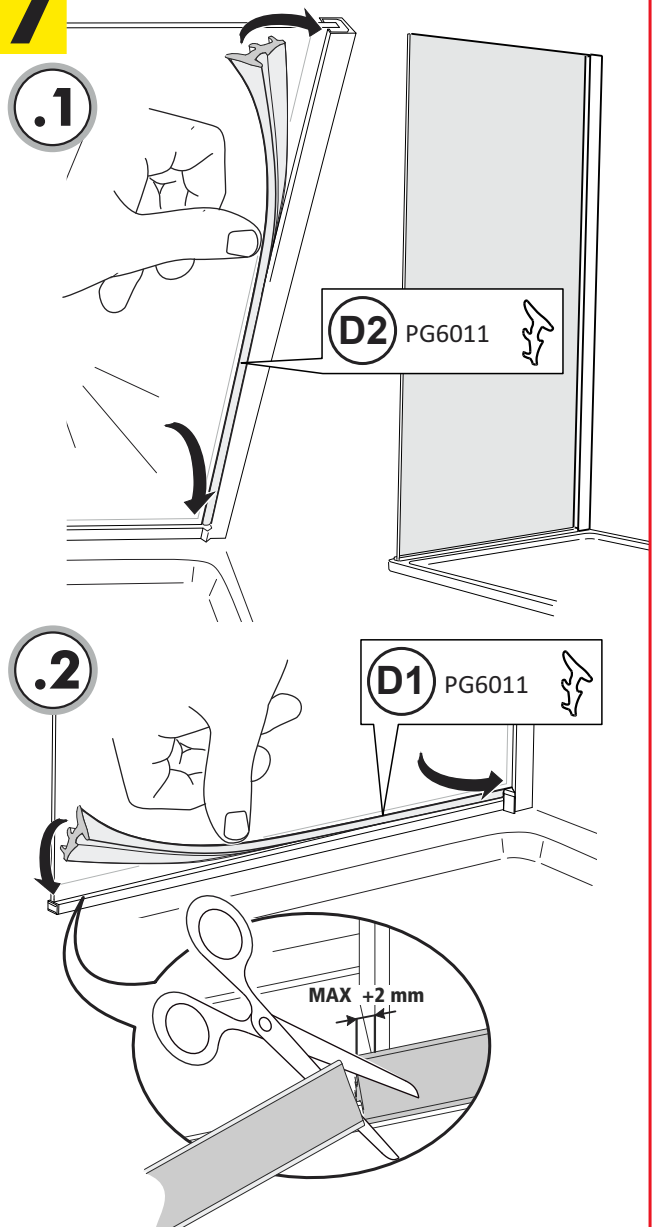

ATTENZIONE! Installazione lato interno
ATTENTION! Internal side installation

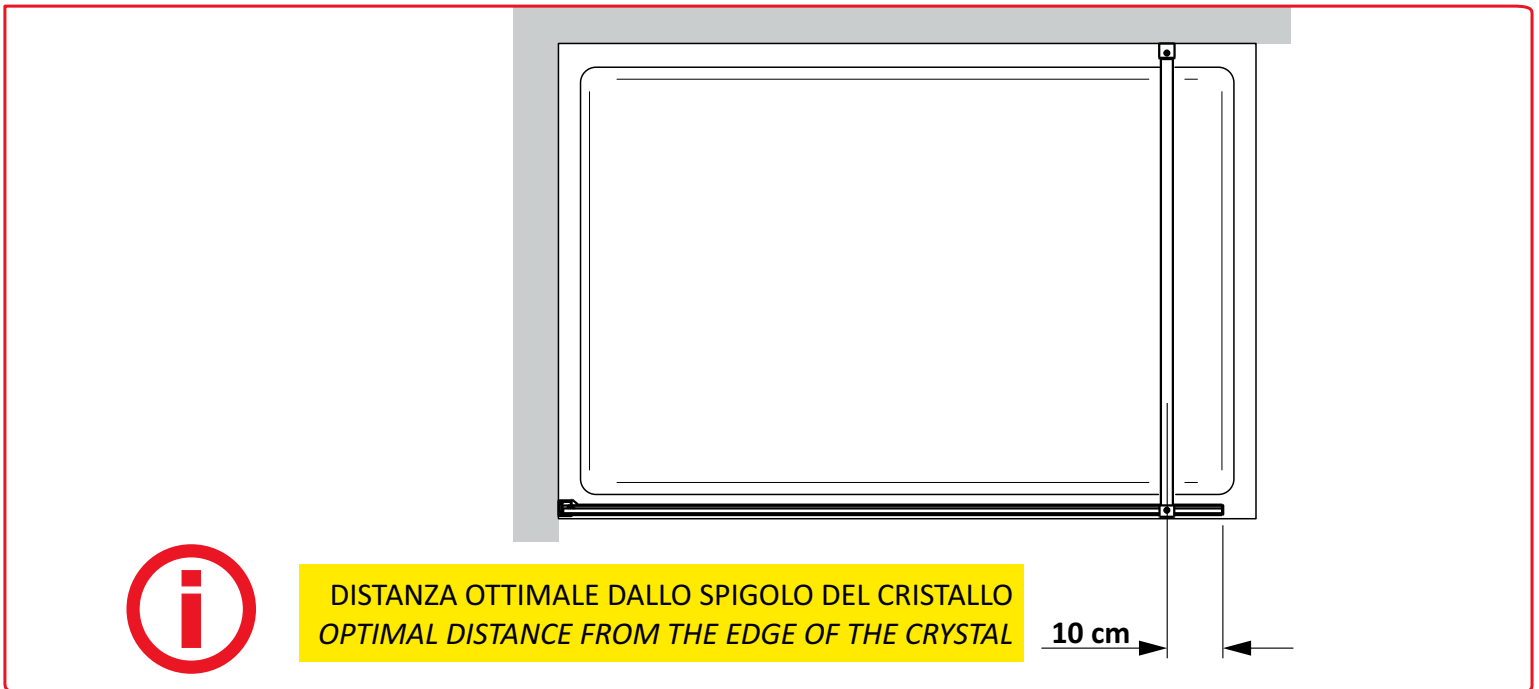
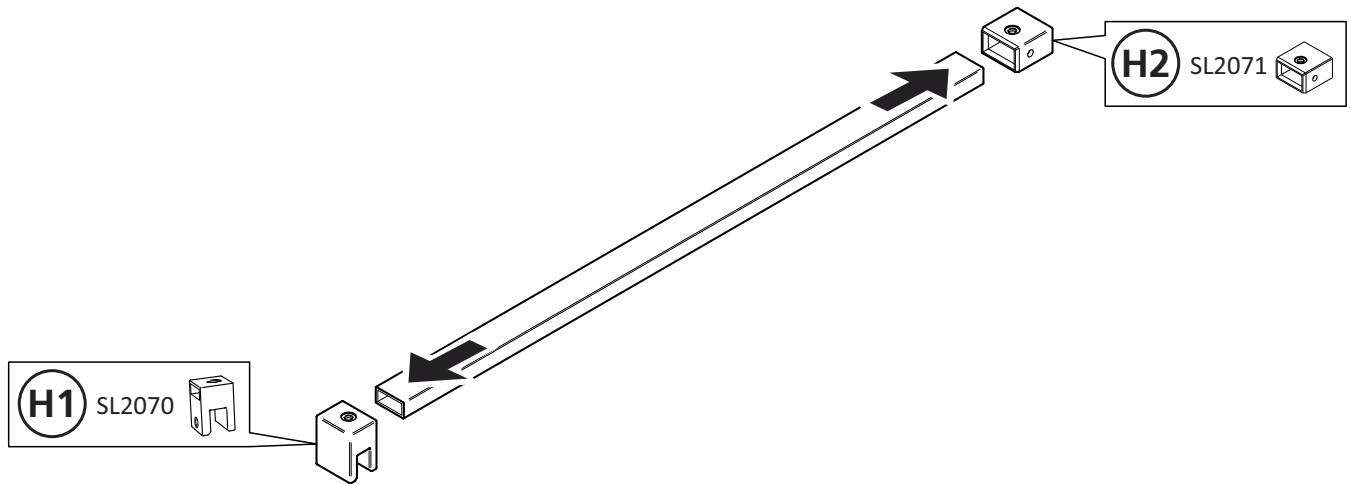
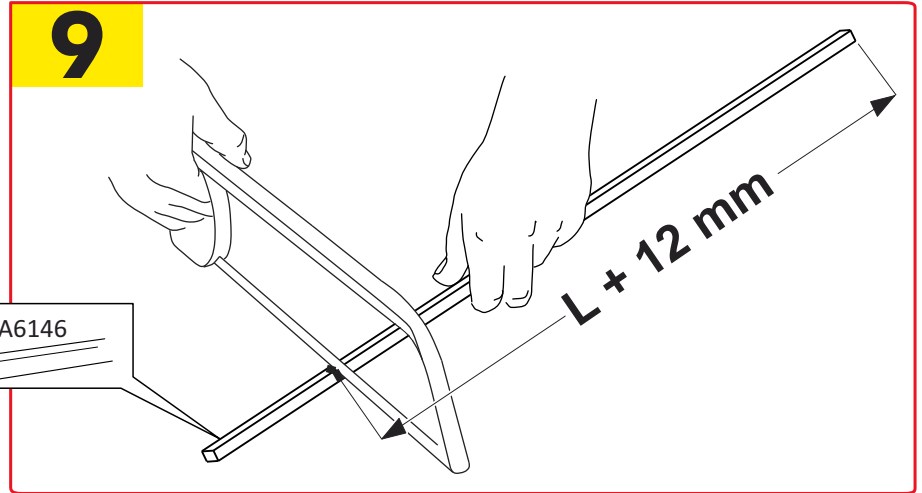
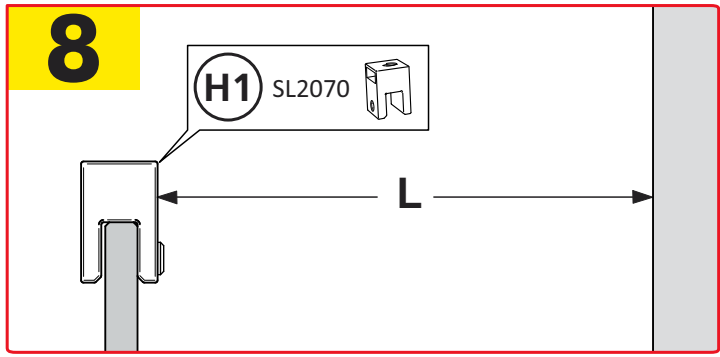
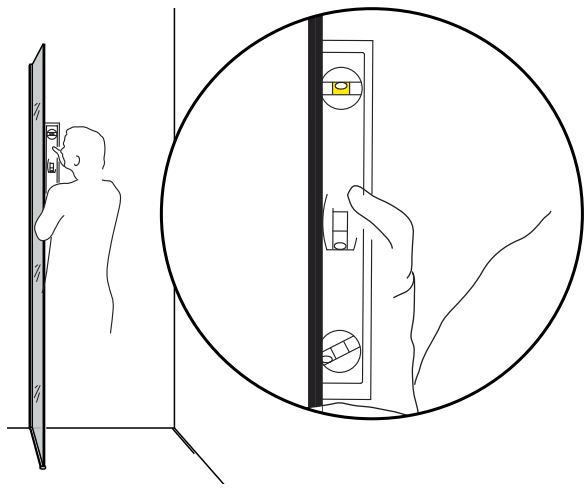

10

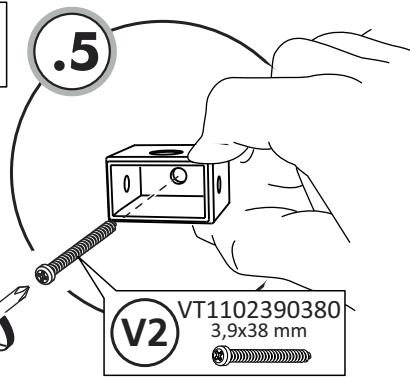
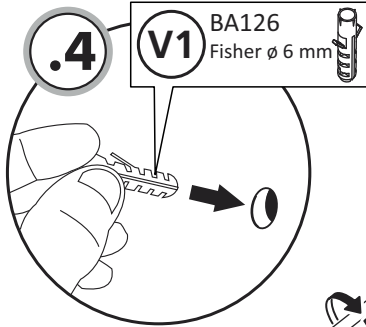
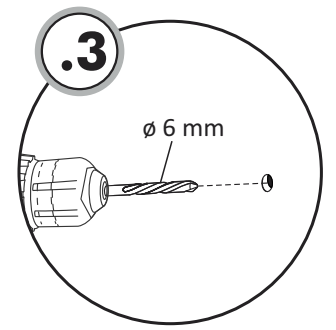
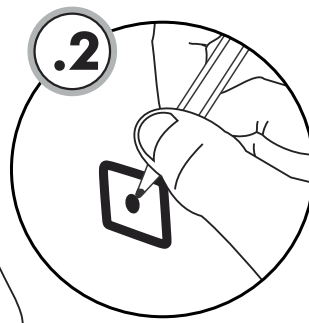
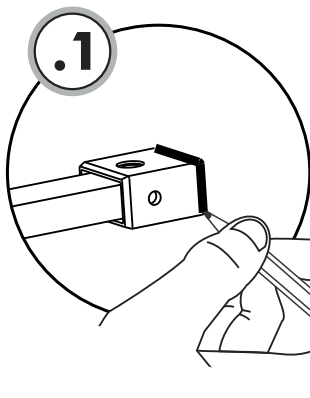
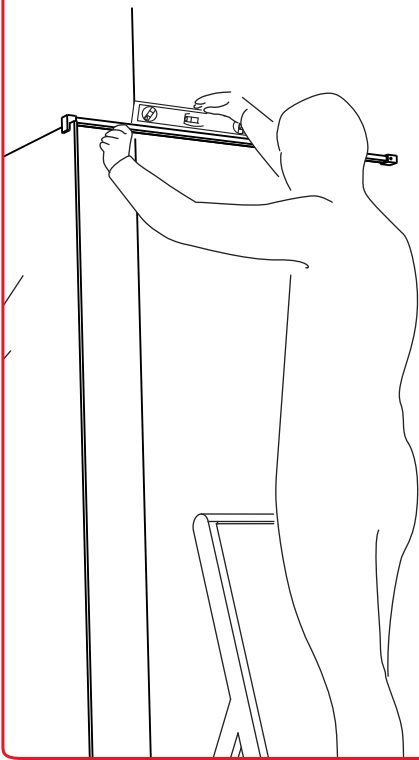

V1 BA126
Fisher \varnothing 6 mm

V2 VT1102390380
3,9x38 mm

11

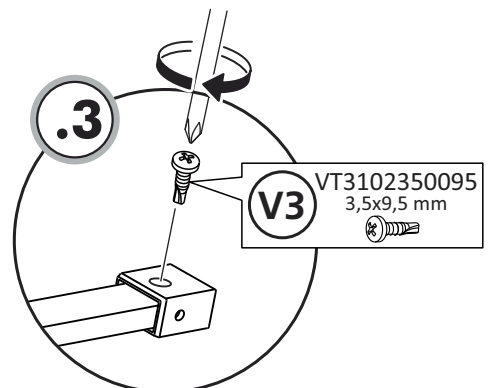
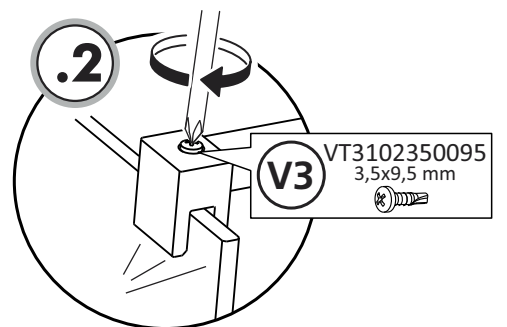
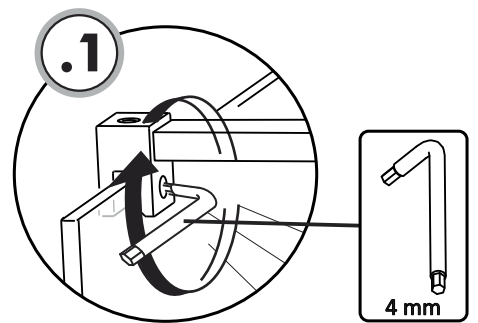
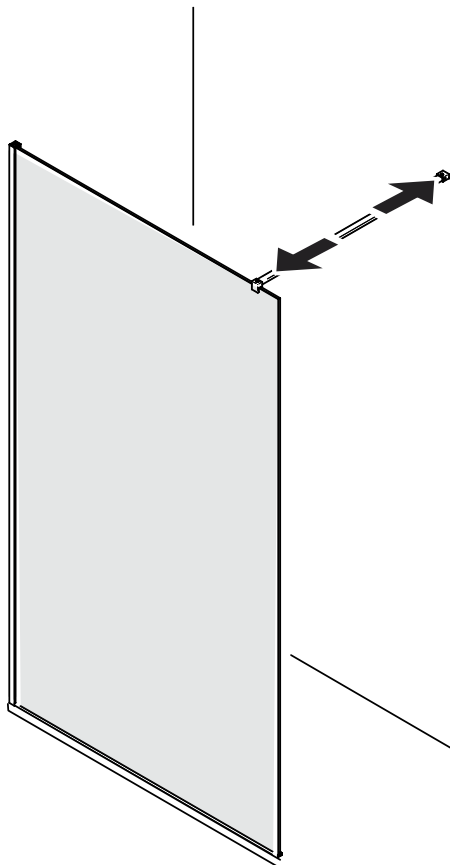

4 mm

V3 VT3102350095
3,5x9,5 mm

V3 VT3102350095
3,5x9,5 mm



24 h

